

## Contents

**Description** \_\_\_\_\_ Page 2

- Introduction
- Product Photo
- Feature

**Function / Specification**

- Trigger Mode Description \_\_\_\_\_ Page 3
- Electronic Spec. \_\_\_\_\_ Page 4

**Hardware description**

- PCB Diagram \_\_\_\_\_ Page 5
- Jumpers / Connectors Description \_\_\_\_\_ Page 5
- Operation Note \_\_\_\_\_ Page 6
- Connectors Diagram \_\_\_\_\_ Page 6
- PCB Dimension Diagram \_\_\_\_\_ Page 7

**Housing Description**

- Metal Box Dimension Diagram \_\_\_\_\_ Page 8
- Metal Box Photo \_\_\_\_\_ Page 9

Hwan Maw Technology Co., Ltd.

Tel.: +886-2-2274-1347 Fax. +886-2-2273-3014

[Http://www.hmt.com.tw](http://www.hmt.com.tw) e-mail: [hmtsales@hmt.com.tw](mailto:hmtsales@hmt.com.tw)

## VCM-Series Product Data Sheet

Model Name: **VCM-CF380 Digital Voice Module**.....Rev. C

### Introduction

**VCM-CF380** is a digital voice module even a **fully automatic schedule announcement device**. It's **built-in RTCC, stand along time saving and playback digital sounds**.

It directly plays back 8/16-bits mono PCM sound files digitized at 8, 11, 16, 22.05, 24, 32, 44.1 KHz. Sound files are programmed and stored in Compact Flash Card for instant, random access. There is no restriction on the length of each sound as long as the total length of all sounds combined fit to the CF Card.

The board is designed to be a standalone device and powered by a single voltage supply. Sound playback can be triggered by a number of devices such as push buttons, motion sensors and dry contact closures. As well can be an automatic announcer. The built-in power amplifier can deliver up to 5W into a speaker, with a volume control tuner.

The board can be configured to operate in different modes. The configuration data is stored in CF Card memory along with sound bytes. On power up the board will configure itself automatically. There is no need to set switches manually.

There are many Playback Modes: Direct Single, Direct Single of Cycle, Binary, Parallel and Serial modes. All of input modes are selected via CF Linker Software Tool.

How can I set the target time and automatic announcements for certain schedules? Don't worry! The VCM-Series development software can have the settings completed.

It's multi-function and easy to operate.

### Feature

- \*Max. Quantity of Messages:
  - 28/32 Messages in Direct Single Mode
  - 255 Messages in Binary or Serial Mode
  - 7424 Messages in Serial ASCII Mode
- \*Memory Type: Compact Flash Card.
- \*Max. Memory Capacity: Up to 2GB
  - 23 Seconds at 44.1KHz / 8BITS(Per 1MB)
  - 6 Hours at 44.1KHz(1GB)
- \* Voltage Supply: 11~36 VDC, 1A
- \*Output Amplifier: 5W (Ro = 4 ohm)

### Product Photo

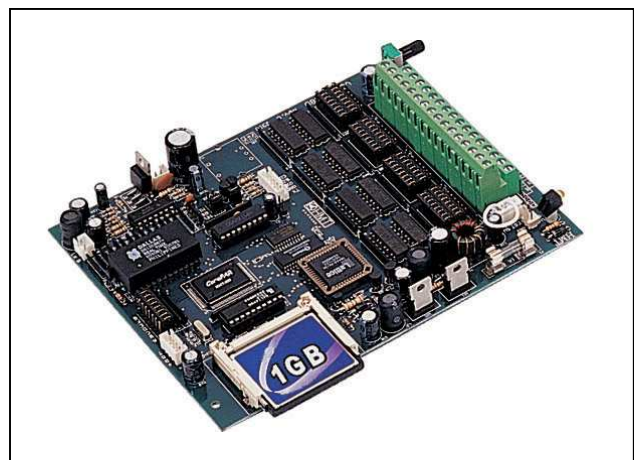

## VCM-Series Product Data Sheet

Model Name: **VCM-CF380 Digital Voice Module**.....Rev. C

### Function / Specification

Input trigger pins number	28 pins, Photo coupler isolated
Input trigger acknowledge	High/Low with jumper selections
Exterior response signal	Busy signal and EOV signal
Memory type	<b>Compact Flash Card</b>
Memory capacity	Max: <b>2GB</b>
Sampling rate support	11KHz / 16KHz / 22KHz / 24KHz / 32 KHz / 44.1KHz, 8 bits / 16bits
Message length	23 seconds / MB (With 44.1KHz / 8 bits)
Max. quantity of message	<b>8192</b> messages. (Input Trigger mode With Serial ASCII)
Max. address quantity of digital voice files	<b>8192</b> files. (Input Trigger mode With Serial ASCII)
Properties for every message	Edge / Level , Hold / Unhold , Interrupt / Non-interrupt (All of trigger points independence setup. )

#### Trigger Mode Support / Trigger Pins Description / Max. Quantity of Message

Single segment mode	X0-X27 / X0-X31	28/32 messages
Single Circulating mode	X0-X27 / X0-X31	28 messages
Binary code mode with strobe signal	X0-X7, Strobe: X8 X0-X9, Strobe: X10	255 messages (8bits) / 1023 messages (10bits)
BCD code mode with strobe signal	X0-X7, Strobe: X8	100 messages
BCD code mode without strobe signal	X0-X7	99 messages
Parallel of binary code mode without strobe signal	X0-X7	254 messages (8bits) / 1022 messages (10bits)
Binary Serial code mode	RS-232 PORT #1	255 messages
Binary Serial frame mode	RS-232 PORT #1	255 messages
ASCII Serial code mode	RS-232 PORT #1	<b>7424</b> messages
<b>RTCC mode</b>	No Input Pins	128 messages

## VCM-Series Product Data Sheet

Model Name: **VCM-CF380 Digital Voice Module**.....Rev. C

### Electronic Specification

Voltage Supply	DC 11 - 36 V / 1A (DC-DC)
Amplifier Output	3 watt, Ro = 4 ohm
Consumption (Audio Output)	0.6A at DC 24 Vin
Consumption (Without Audio Output)	130mA at DC 24V
Trigger Inputs De-bounce Time	Signal length 80ms at least.
Watch Dog Function	Yes
Operating temperature	0°C - 70°C
Line Out	Yes
Volume Control	Yes
Serial baud rate and format	2400 bps / 4800 bps / 9600 bps, N, 8,1
Serial signal level	Tx : TTL , Rx : TTL / RS-232 / 12V-0V
PCB Dimension (L x W x H)	174 x 137 (mm)
Metal Box (Option)	Yes

# VCM-Series Product Data Sheet

Model Name: **VCM-CF380 Digital Voice Module**.....Rev. C

## PCB Diagram / Jumpers & Connectors Description

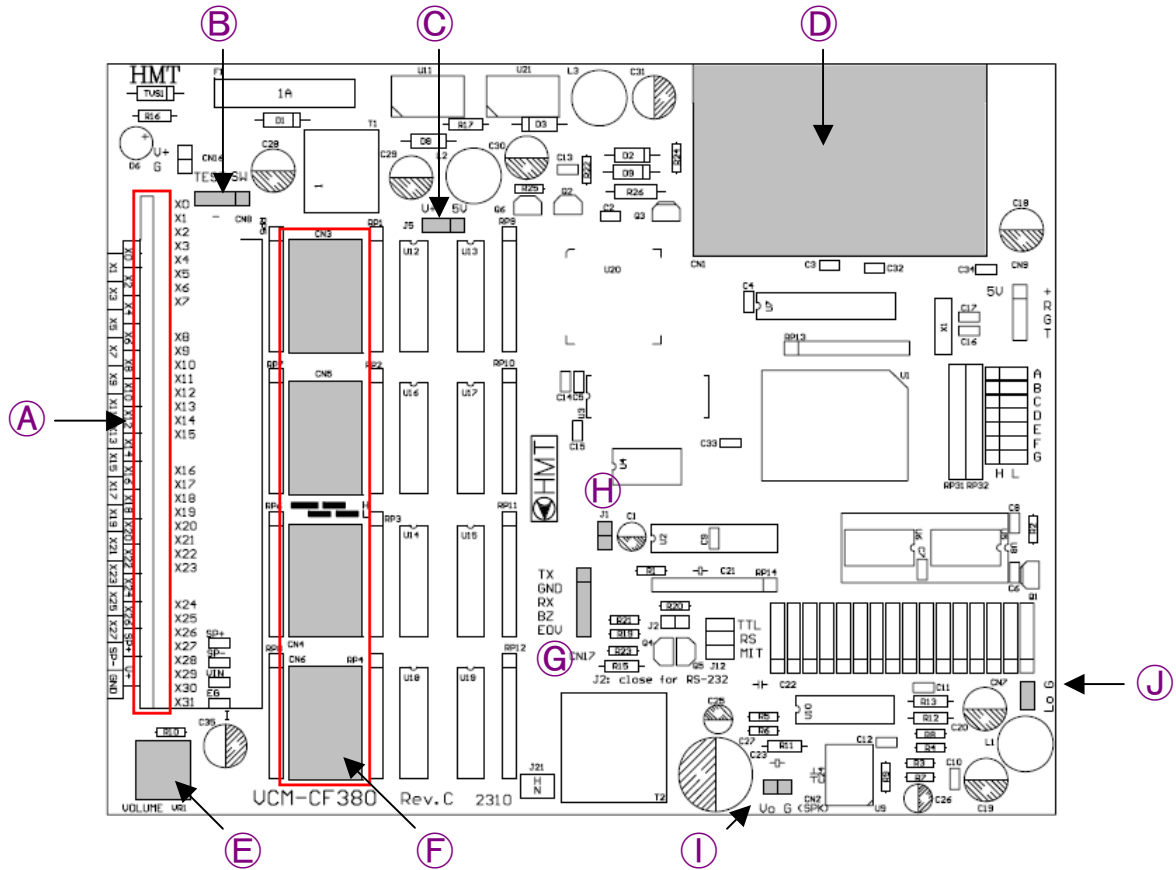

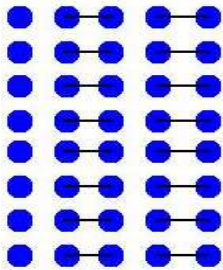
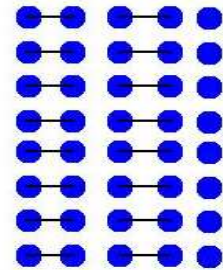
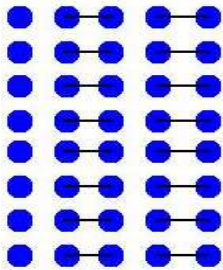
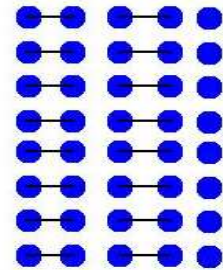
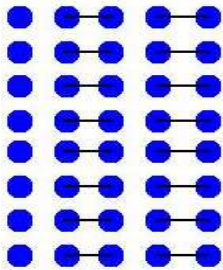
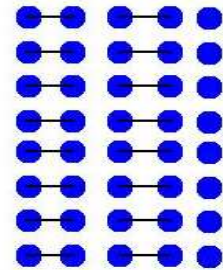
A	Input Pins Information. (With screw on top connector.) See PCB label: Input Trigger Pins : X0-X27/ X31 Sp+ / Sp- : Audio Output.    V+: Power Supply DC:11-36 V, 1A    GND: Ground. (0V)					
B	CN7: To connect Switch.(For Box Useful)	G CN7: To Connect extra module.				
C	J5, Normal short at 5V side	H J1: System Reset.				
D	CF CARD Socket.					
E	Volume Controller					
F	By placing the jumpers to certain ports when select which trigger Level is used.  <Default: Low Trigger> <table style="width: 100%; text-align: center;"> <tr> <td style="width: 50%; color: blue;">Low Voltage Trigger</td> <td style="width: 50%; color: blue;">High Voltage Trigger</td> </tr> <tr> <td></td> <td></td> </tr> </table>		Low Voltage Trigger	High Voltage Trigger		
Low Voltage Trigger	High Voltage Trigger					
						

# VCM-Series Product Data Sheet

Model Name: **VCM-CF380 Digital Voice Module**.....Rev. C

## Operation Note

When Power supply is on, the system should sound out “Beep! Beep! (two times)” It represents the P.C.B. and EPROM data programming are ready. If not, please check out CF-link software setting and all connections.

## Connectors Diagram

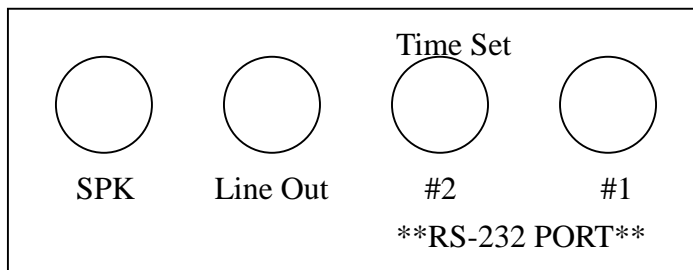

## Description

Label Name	SPEC.	Function	Remark
SPK	3.5mm Jack	Audio Output	-----
Line Out	3.5mm Jack	Line Output	-----
RS-232 PORT #1	3.5mm Jack	Time set. To use VCM-CF TTY Terminal Software Tools.	Use Communication cable, [D-SUB (9PINS to Jack.)]
RS-232 PORT #2	3.5mm Jack	Serial Communication For input trigger used only.	Use Communication cable, [D-SUB (9PINS to Jack.)]

# VCM-Series Product Data Sheet

Model Name: **VCM-CF380 Digital Voice Module**.....Rev. C

## \*\*\*PCB DIMENSION\*\*\*

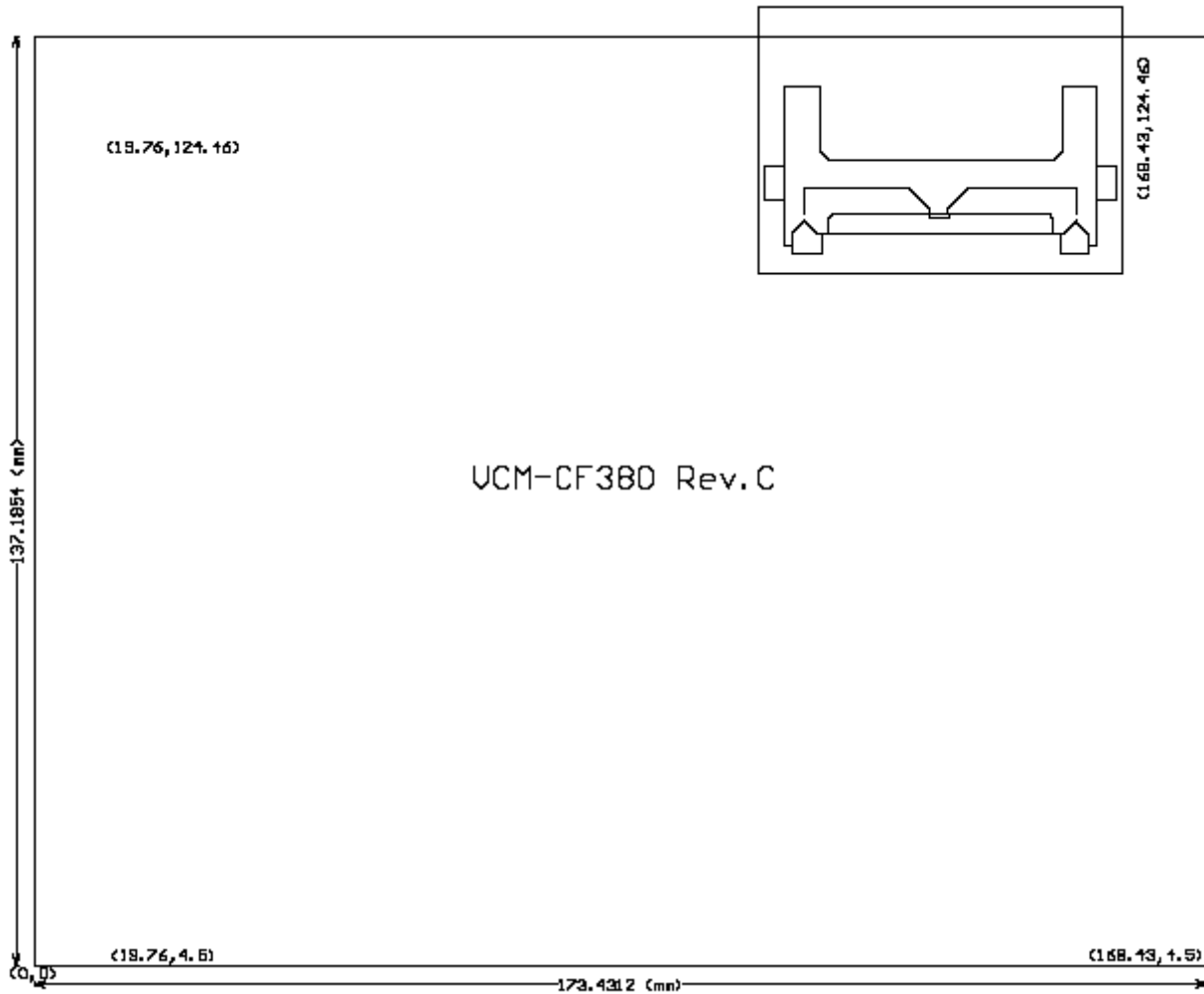

# VCM-Series Product Data Sheet

Model Name: **VCM-CF380 Digital Voice Module**.....Rev. C

## Metal Box Dimension Diagram

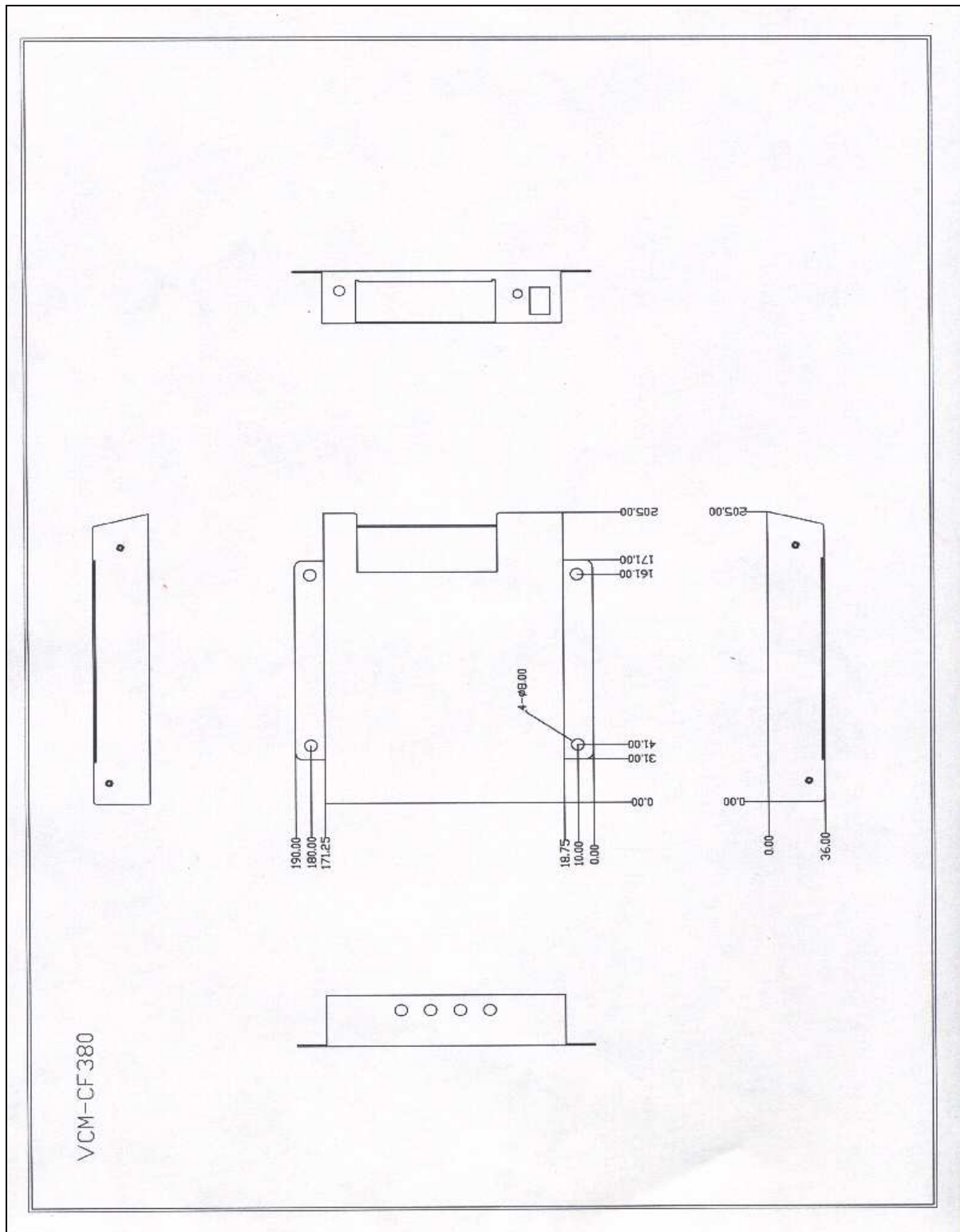



# VCM-Series Product Data Sheet

Model Name: **VCM-CF380 Digital Voice Module**.....Rev. C

## Metal Box Photo

